

INSTALLATION & CARE GUIDE

A step-by-step guide
on installing & caring
for your new
composite decking



fyldegrass.co.uk // sales@fyldegrass.co.uk



TABLE OF CONTENTS:

1. BEFORE YOU INSTALL

- How to handle the decking 1
- Correct tools 2
- Things to consider 3

2. INSTALLATION GUIDE

- Spacing the Boards and Subframe 4
- Decking Boards 5 & 6
- Last board 7
- Picture Framing 8
- Edging Trims 9
- Decking Steps 10 & 11

3. CARE GUIDE

- Routine Cleaning 12
- Stubborn Spot Stains
& Surface Mildew Growth 13
- Water Staining 14
- Clearing Ice and Snow 15

4. FAQ'S 16



BEFORE YOU INSTALL

How to Handle the Decking...

- 1.** Decking should be stored in a suitable and flat area prior to install if required. In such instances the boards should be stored on battens at a maximum of 400mm centres, this will ensure that the boards are laid flat and will stop them from bowing, scratching, and sitting in standing water prior to installation.
- 2.** If the composite decking boards are being stored they should be covered to maintain a clean surface, if they are being stored outside this material should be non translucent.
- 3.** Take care when moving the boards to ensure not to slide or drop them as this will scratch or damage the boards.
- 4.** When installing do not drag or drop equipment across the material.

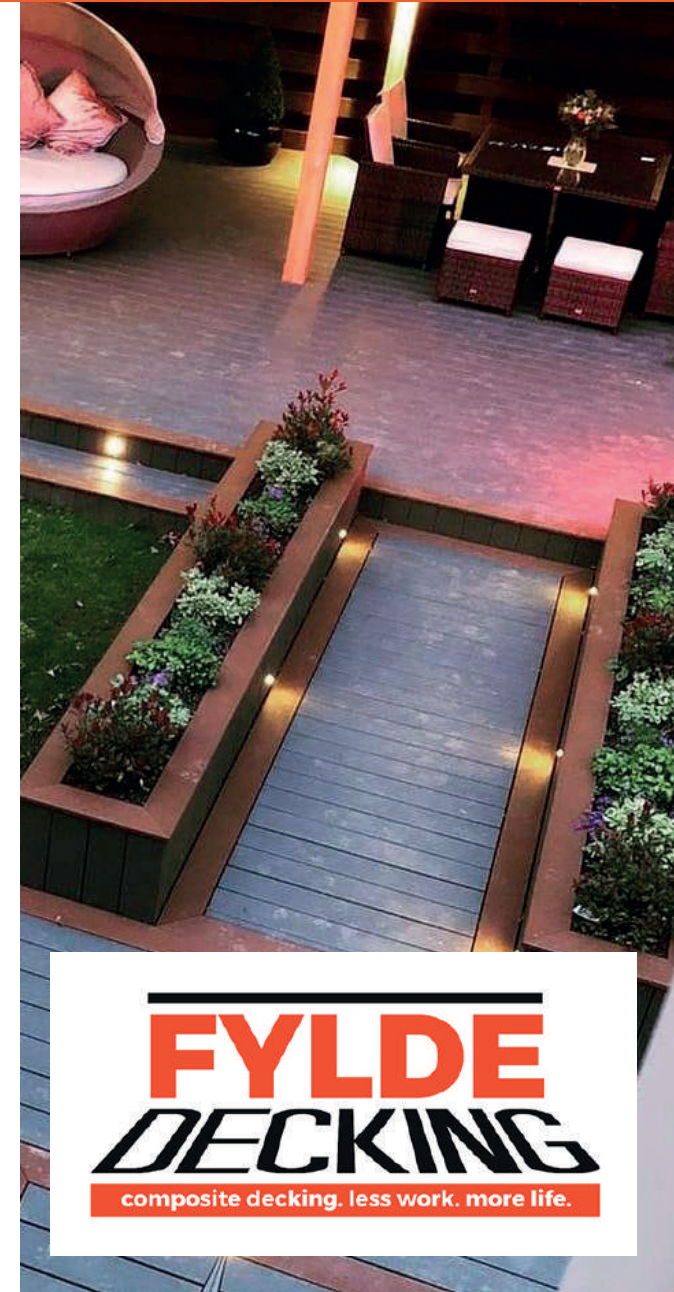

FYLDE
DECKING
composite decking. less work. more life.

BEFORE YOU INSTALL

Using the Correct Tools...



Standard wood working tools can be used with Fylde Decking.

Circular Saw – we recommend a 40 tooth blade to achieve the cleanest cuts

A power mitre saw can be used to create bevelled edges and increase the uniformity of cuts.

Impact Driver or Hand Drill using a low torque setting.

When installing do not drag or slide equipment across the boards.

Tape Measure, Carpentry Square and Spirit Level

Appropriate PPE:

- Safety Goggles
- Dust Mask
- Ear Protection

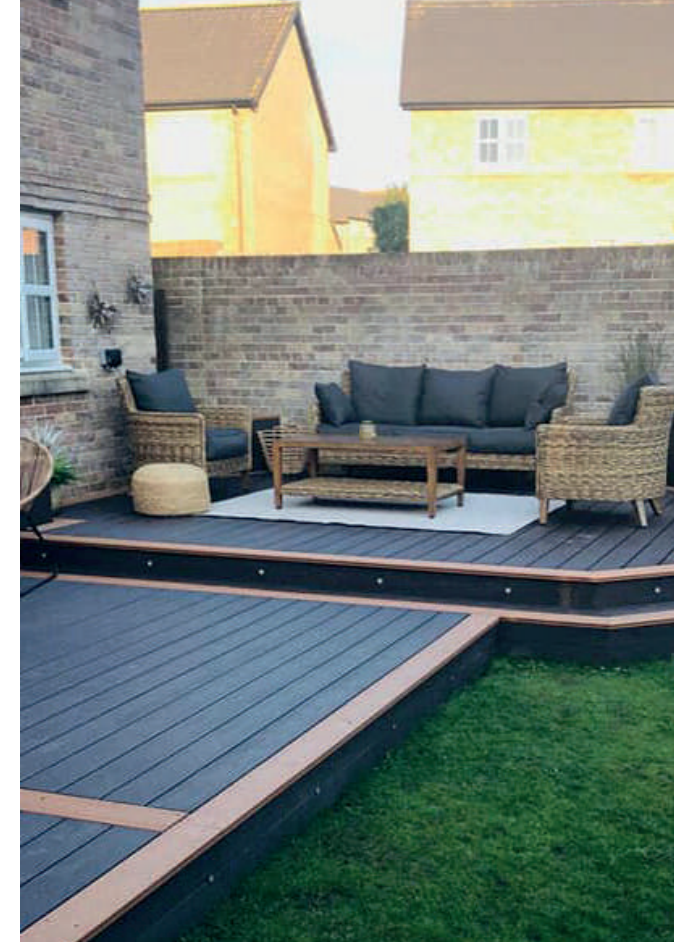

FYLDE
DECKING
composite decking. less work. more life.

BEFORE YOU INSTALL

Things to Consider...

Pre Planning - The size, shape and orientation of the deck should be well considered as part of the initial phase of your project.

The laying pattern of your boards will dictate the placement of the joists and centres, special attention should be paid to boundaries and doors which will open onto the deck, as these may create certain limitations.

TEMPERATURE:

Composite decking naturally contracts and expands when temperatures change. The T clip and screw system dictates the space for expansion to occur. These gaps must also be left on end to end joins and when meeting an external boundary (i.e. a wall), see table on right for installation temperatures.

SUBFRAME:

Our decking should never be installed without a suitable subframe, all decking boards should be installed onto either a timber, metal or composite framework. Always allow a 40mm space beneath the decking subframe to allow adequate airflow under the deck.

COLOUR:

The decking will have an initial 'fade back' within the first 3 months of installation this is as a result of the tannins from the wood material reacting to the weather. Once this process has taken place the change in the colour thereafter will be nominal. There may also be a colour difference in the edging/corner trims and the boards especially if you are installing the boards on the woodgrain side, once the boards have had there initial fade back this difference will be much more subtle.

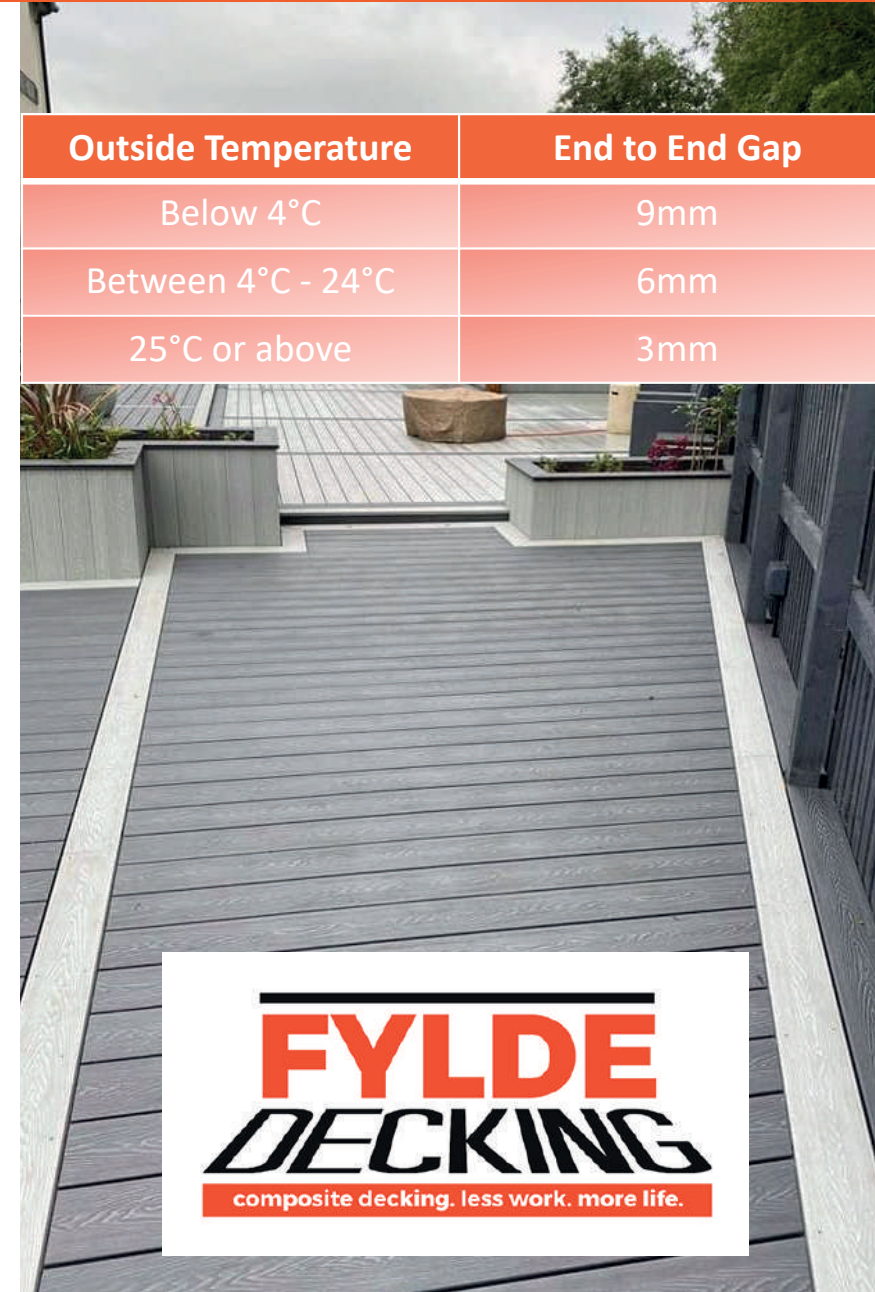

FYLDE
DECKING
composite decking. less work. more life.

INSTALLATION GUIDE

Spacing the Boards & Subframe...

Fylde Decking boards should have a minimum of **3mm gap between the boards**, recommended to be 6mm - 10mm dictated by the T-clip and screw system provided

End to end 'butt joints' should have a min gap of 6mm.

This is temperature dependent see fig on previous page for guidance.

Joist centre supports for the boards should be a maximum of 350mm.

All end to end joints should be supported by two centre joists one for each board and should be clipped at the end of each board.

A drainage run off of 0.5% gradient per m should be made to ensure appropriate water run off.

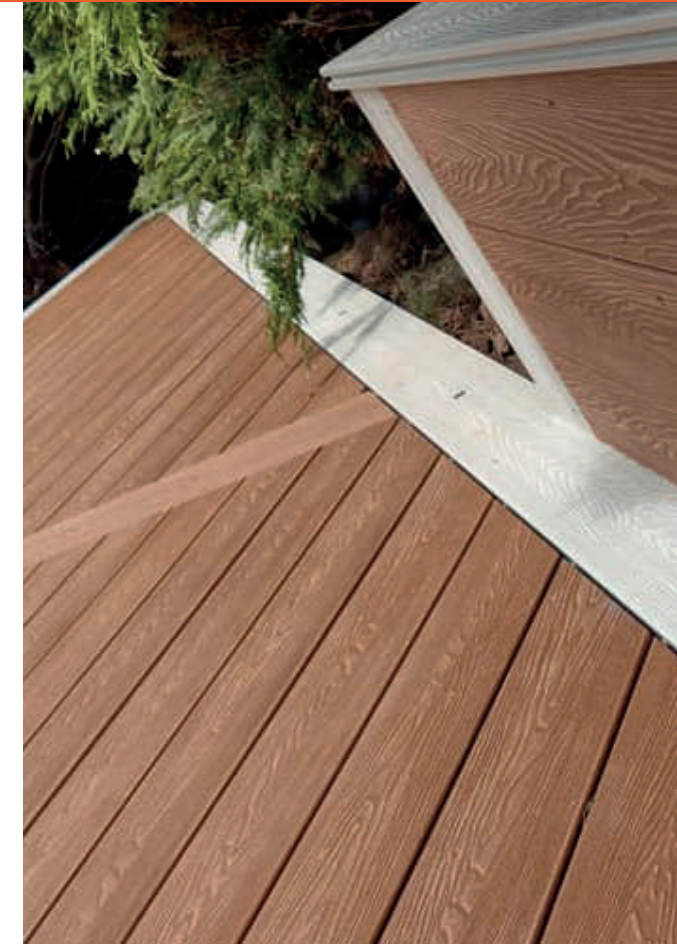
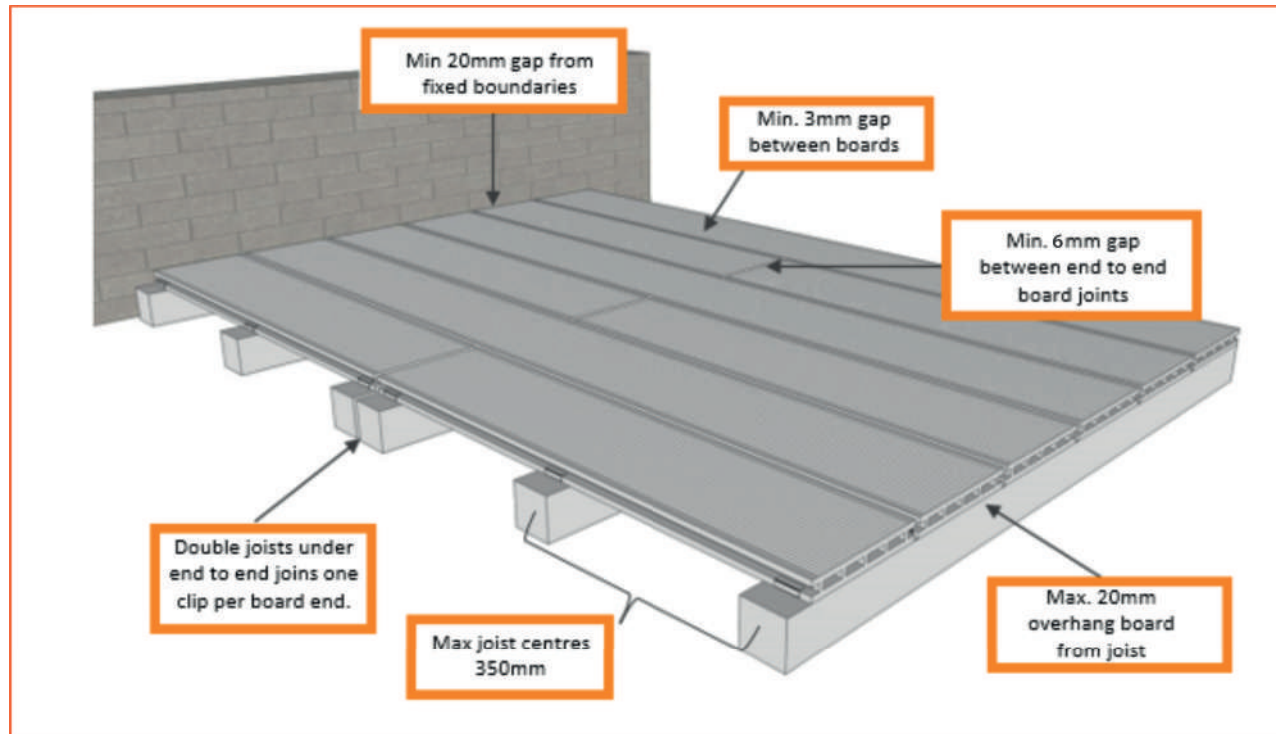

FYLDE
DECKING
composite decking. less work. more life.

INSTALLATION GUIDE

Making a Start...

Once you have **securely laid and levelled your subframe** you can then start to install your decking boards.

Starting at the outside edge of the decking project, begin attaching Starter Clips to the edge of your framework using the steel screws provided. (fig 1)

Counter sinking is recommended to assist with the insertion of the screws.

Position starter clips at every 350mm of the joist length to ensure secure fixings. Clip the first board into the Starter Clips. (fig 2)

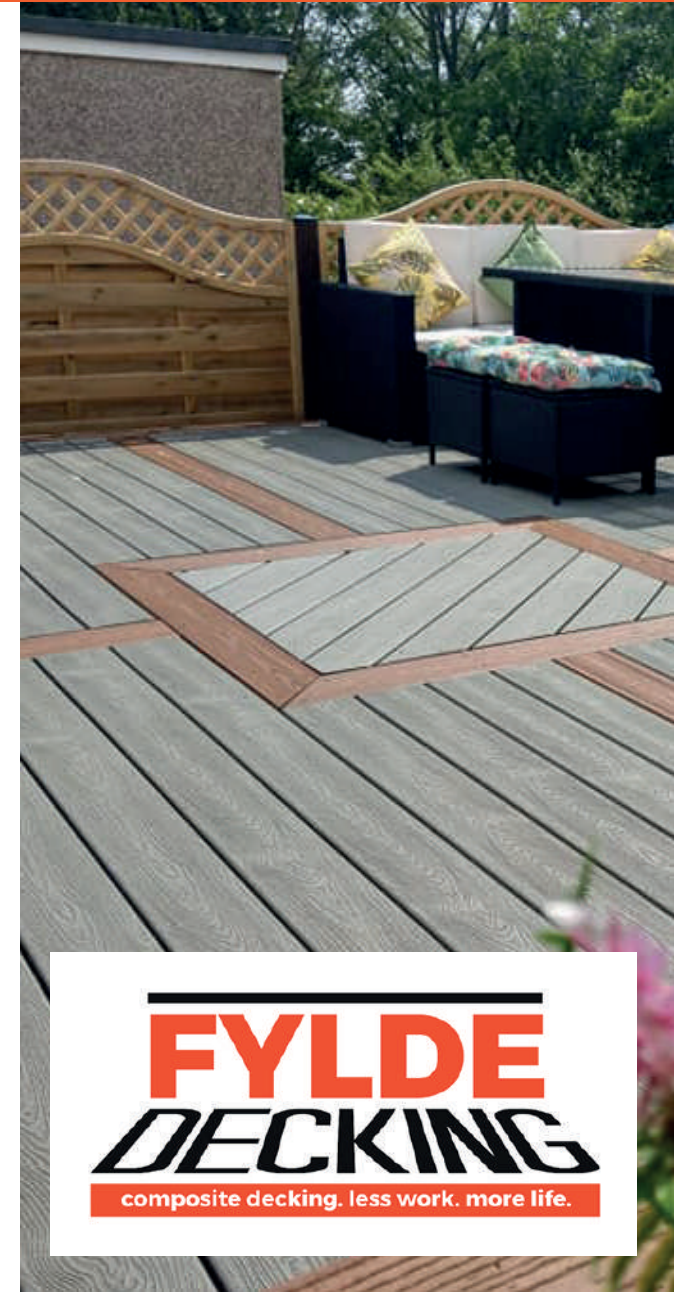
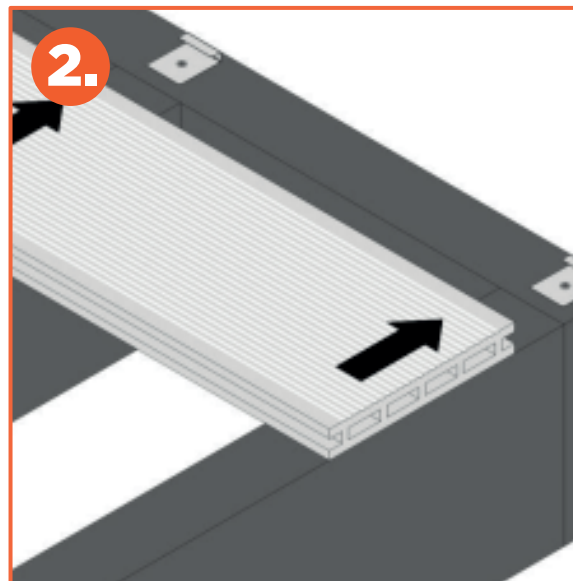
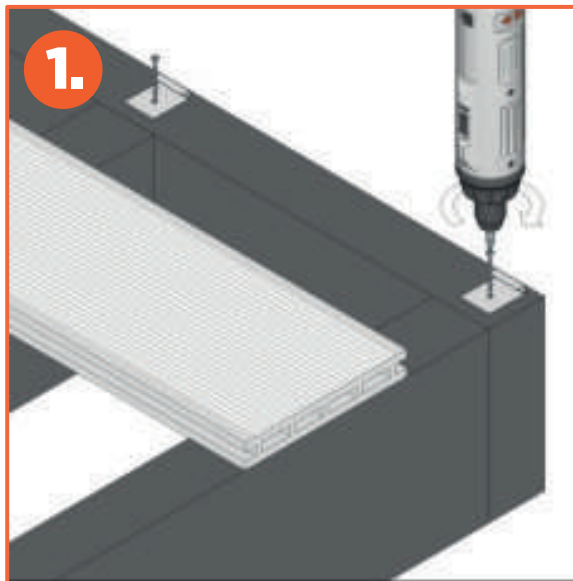

FYLDE
DECKING
composite decking. less work. more life.

INSTALLATION GUIDE

Screwing the Decking Down...

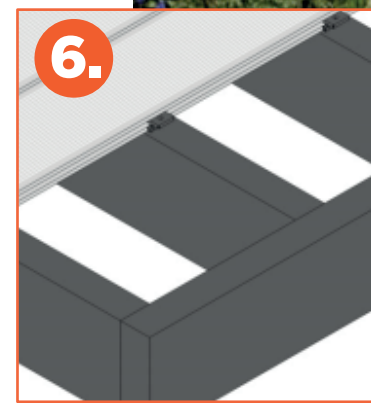
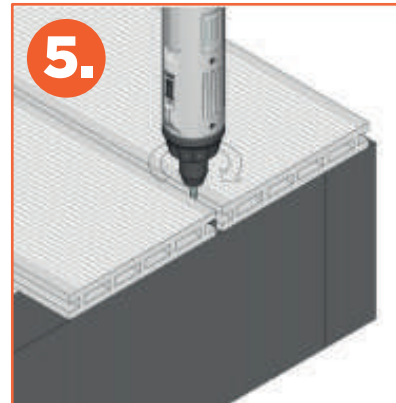
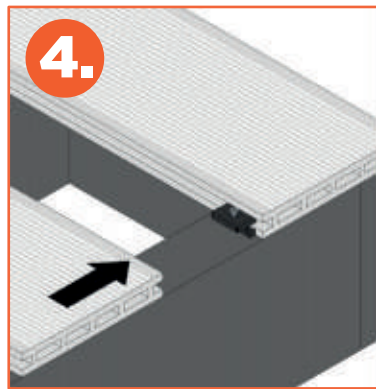
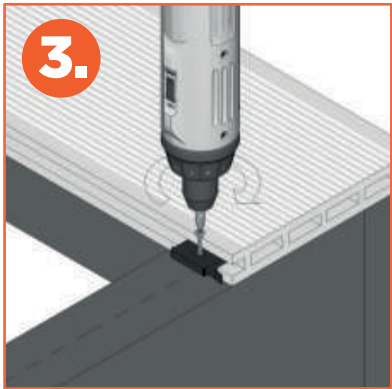

When using the T Clips and Screws lightly screw in place do not tighten at this point. (fig 3)

Then place the next board on your framework against the clips and screws (fig 4) you may need to slightly raise the edge of the board you are installing to slide it into the clips, make sure that the deck board is touching your clips all the way along its length.

Clips should be placed at every 350mm.

You can now fully tighten your t clips and screws, between the boards you just installed. (fig 5)

Repeat steps 3, 4 and 5, until you get to the last 2 boards (fig 6)

FYLDE
DECKING
composite decking. less work. more life.

INSTALLATION GUIDE

The Last Board...

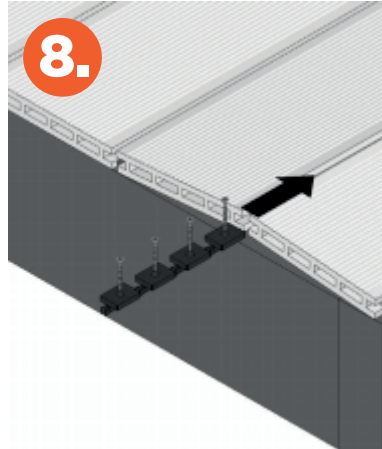
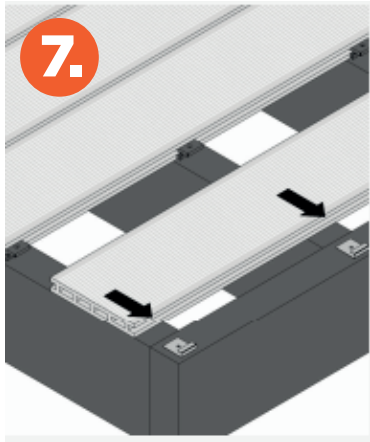

Measure the width of the last two boards with the 6mm spacing gap in between them, mark this on your last joists, using this mark install your Steel Finishing clips. Then clip your last decking board in place. (fig 7)

Once the final board is in place you can then insert your other board, once the two boards are in place with at least a 6mm gap between them, you will then slide down the required amount of T-Clips. (fig 8) screw the clips to the joists.

Alternatively if the install does not allow for the above method to be used you can secure the last board by, (after securing all other boards) screwing through the bottom of the last board at an angle at every 350mm. (fig 9) do not over screw into the deck boards as to avoid the material splitting.

Do not over screw into the deck boards as to avoid the material splitting.

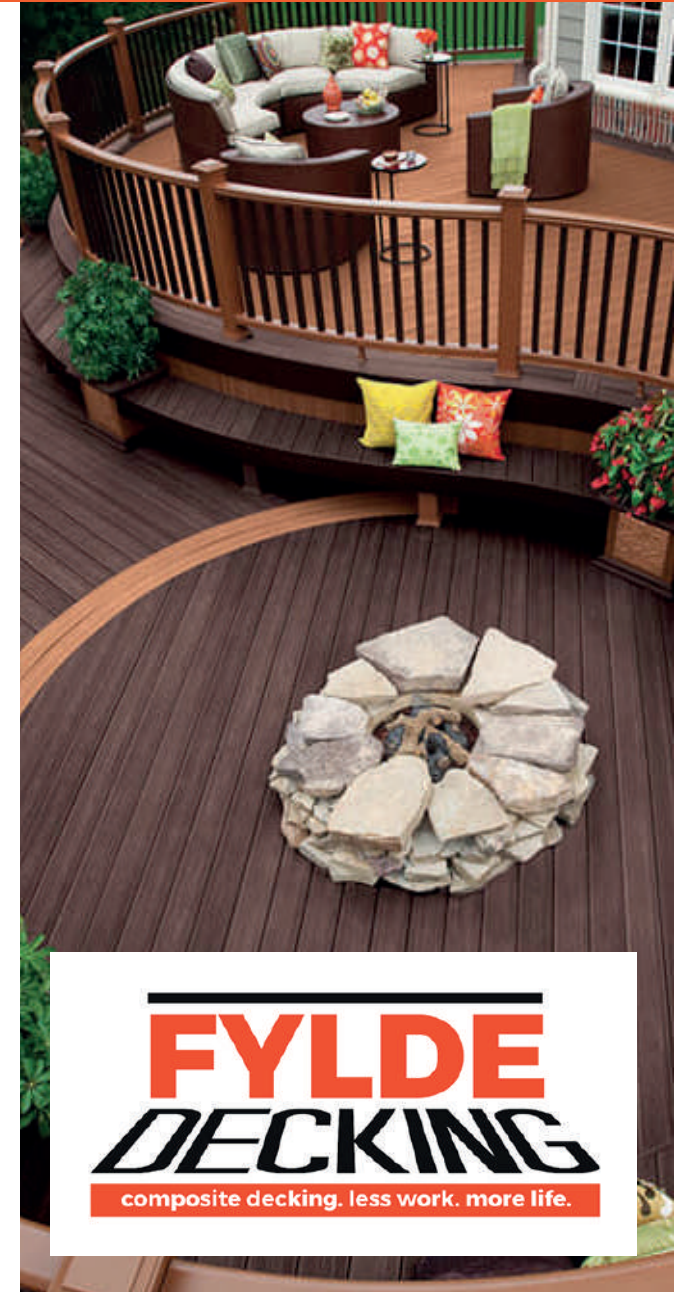

FYLDE
DECKING
composite decking. less work. more life.

INSTALLATION GUIDE

Picture Frame Border...

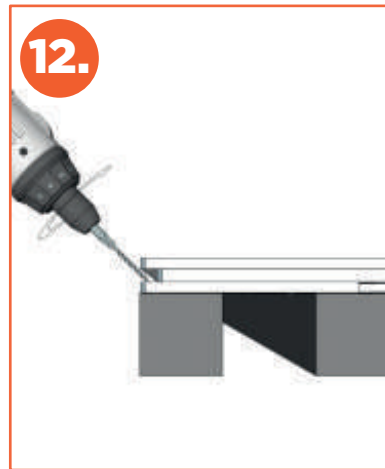

If you are intending on installing a picture frame border then you need to ensure that you **install the correct substructure layout**.

Double joist structures must run under all sides where the picture frame border will run perpendicular to the main deck. (fig 12) When the picture frame is running parallel with the rest of the deck you can install using the method on previous page (fig 3-9). With a 45° mitred edge. (fig 11)

For the boards that run perpendicular to the main deck place starter clips on the inner joists holding the inner board edge in place (fig 10), clips should be installed every 35mm along the length of the joist, you can then slide the board into the starter clips (fig 11). The standard 6-10mm expansion gap between the mitred edges must be left.

When the board is in place you can then screw into the outer edge of the board to secure in place (fig 12)



FYLDE
DECKING
composite decking. less work. more life.

INSTALLATION GUIDE / Edging Trims...



Measure the required amount of Edging trim and cut down to size, mitre down the ends at 45° angles if installing around corners (fig. 13) Cover the deck edge with corner trim and attach with screws

Pre-drill 4mm countersunk pilot holes (fig. 14)

Fix with 50mm countersunk screws (fig. 14)

Do not overdrive screws when through composite products, finish tightening by hand

Corner trim can be screws into the deck however best practice is to use an outdoor/external building/fixing adhesive such as CT1 or Gripfill and reinforce to hold with screws every other foot

Ensure you have left appropriate expansion gaps where corner trim ends meet, **min 4mm.**

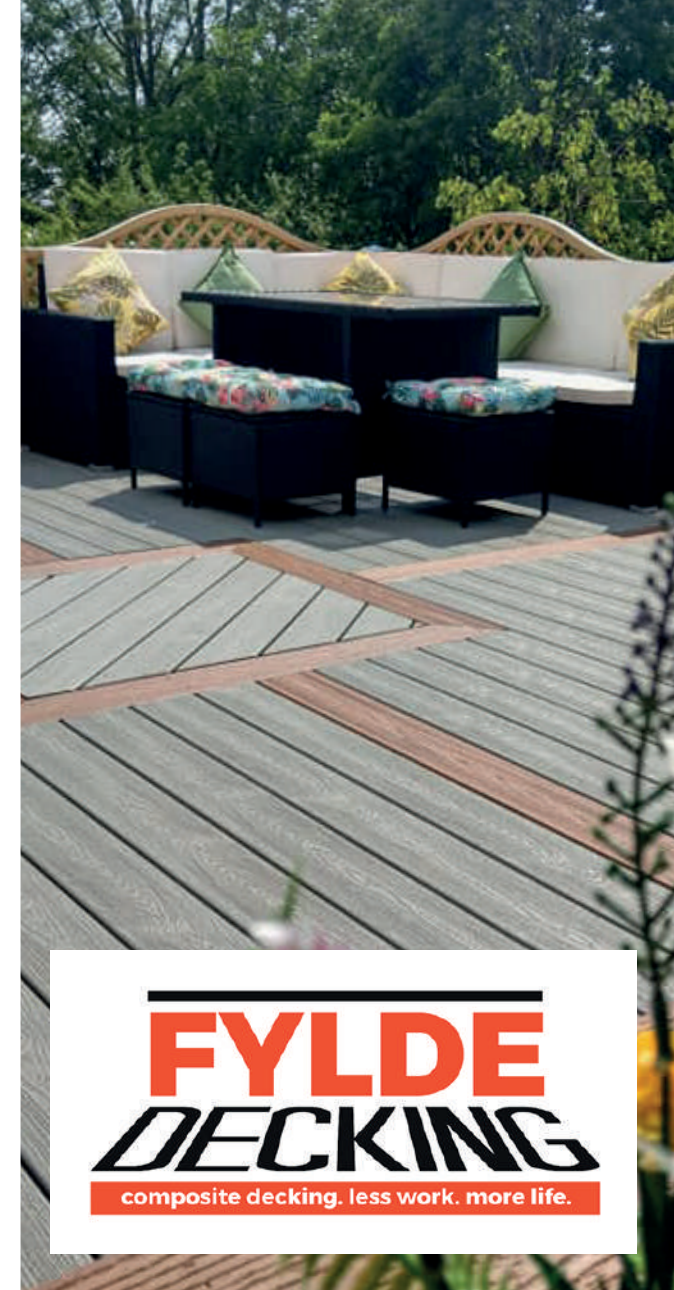

FYLDE
DECKING
composite decking. less work. more life.

INSTALLATION GUIDE

Decking Steps...

Decking steps should be carefully planned to ensure the rise and tread remain consistent along the run:

The rise of the step should not exceed 190mm; the tread of the step must be between 250-450mm deep.

A flat, solid landing pad formed of concrete or gravel is recommended to provide a sufficient level of structural support below your step area. There are two main methods you can employ to install steps to your decking project: **Stringer and Box-Framed Steps.**

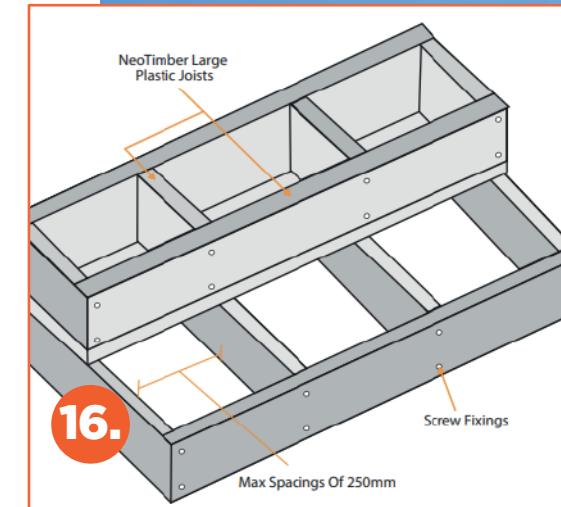
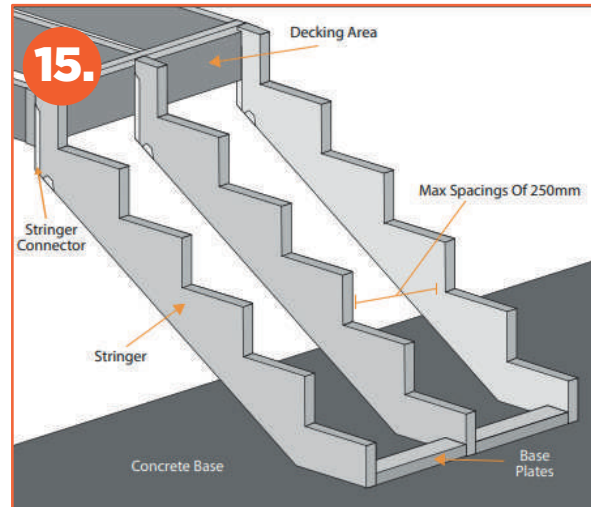

Stringer Steps (fig 15) are most commonly constructed in timber, a stringer is a support that spans from a decking subframe to the base of the step area. A network of stringers form the framework of a step.

Notches should be formed in pressure treated timber and a carpentry square and a saw should be used to form the rise and tread To fix the stringer steps at the base of the steps, anchor the steps with a base plate and attach to the landing pad To fix the stringer steps to your deck area, reinforce the area of the subframe behind the steps with a stair header and install a stringer connector.

Box-Framed Steps (fig 16) Box-framed steps are a series of boxes that are stacked on top of one another to form a run of steps. Form a box framework, infill with joists at 250mm spacings. Box-framed steps can be formed from timber, metal or Plastic Joists. Secure the box-frame to the decking subframe at every intersection using appropriate fixings.

FYLDE
DECKING
composite decking. less work. more life.

INSTALLATION GUIDE /

Decking Steps (cont)...

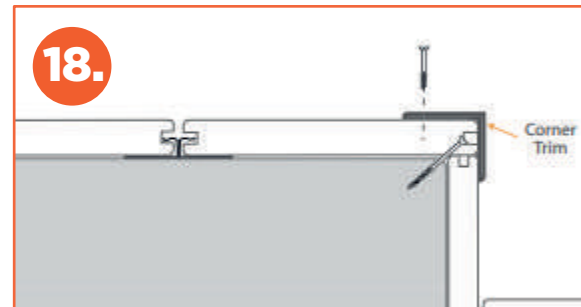
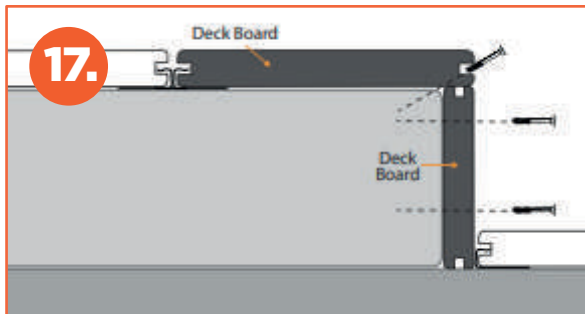

Fix the board to form both the tread and riser of your steps, installing directly onto your step framework using the T-Clip system where able to. Screw fix the exposed grooved edges or face fix the board with a composite screw (fig 17)

Fix the Edging Trim to the exposed edge of the board Cover the deck edge with corner trim and attach with screws (fig 18) Pre-drill 4mm countersunk pilot holes, Fix with 50mm countersunk screws, Do not overdrive screws when through composite products, finish tightening by hand.

Corner trims should only be screwed into the deck.

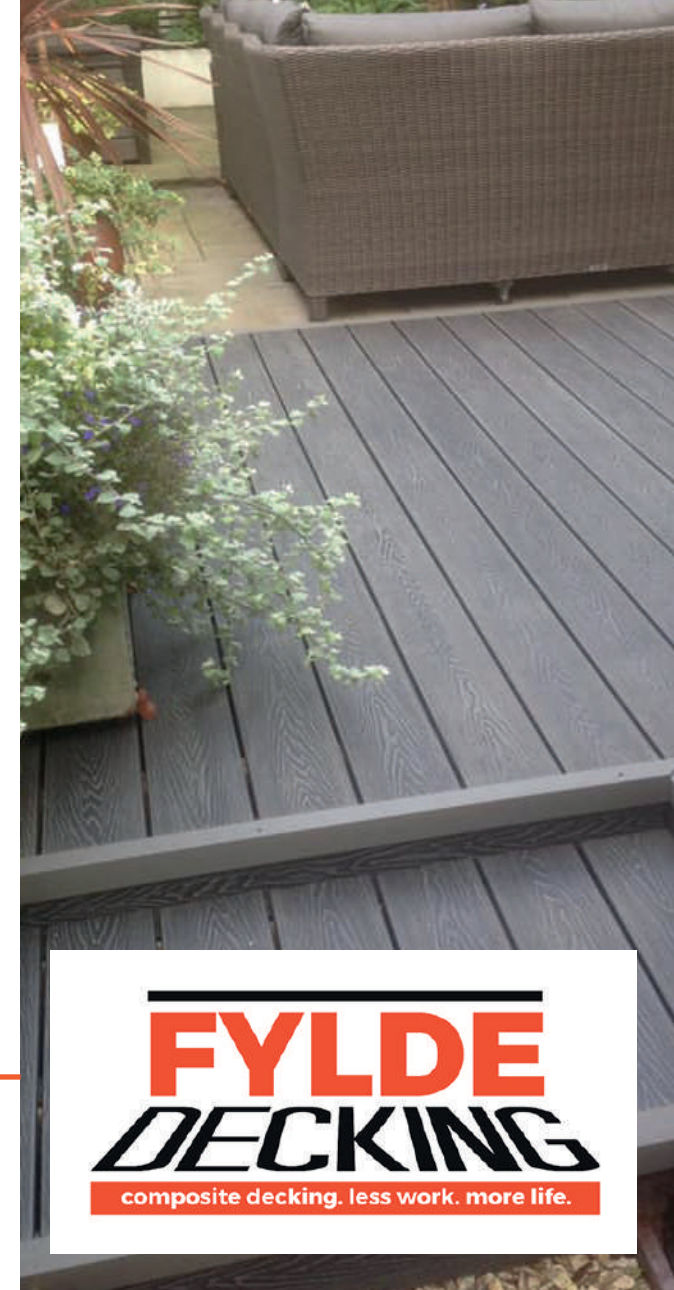

FYLDE
DECKING
composite decking. less work. more life.

CARE GUIDE

Routine Cleaning...



Our composite products are low maintenance, however with a little cleaning you can help keep your outside space looking beautiful for longer.

Routine Cleaning Fylde Decking recommend a routine clean of your decking every 3 months to clear away dirt, mud and soil that can accumulate and sit on your boards over the course of time.

For a general clean - We recommend applying warm soapy water to the surface of the boards and cleaning with a soft bristled brush.

For a deeper clean - You can opt for using a jet wash with no greater than 1500 PSI to clear surface debris from your deck. Using the fan attachment, ensure that this is not applied any closer than 150mm (6 inches) away from the surface of the boards. Following these tips will ensure you preserve the long-term finish of the board.

Regardless of which cleaning option you choose, be sure to clean **along the length of the boards** to avoid accumulation of material that can interfere with drainage



FYLDE
DECKING
composite decking. less work. more life.

CARE GUIDE

Stubborn Spot Stains & Surface Mildew Growth...

Many stains can be cleaned with soap or household de-greasing agent and warm water. **Scrub and soak the affected area** as soon as the stain occurs to ensure best results, then rinse off with warm water.

For more stubborn stains we recommend using a composite specific cleaner for more effective stain removal. Only with very set stains, you may want to use coarse sandpaper (60-80 grit) and sand lightly, always in the direction of the grain of the product (be careful when sanding the wood grained decking as this can remove the enhanced wood grain effect).

Cleaned or sanded areas may lighten, which can require 8-10 weeks exposure to the sun to match the remaining product, depending on location and specific application. Due to the wood content, composite products, like any wood-based product, may experience a naturally occurring process called extractive bleeding (known as tea staining). **This process can cause a temporary discoloration that will fade with time.**

While our boards are resistant to the damaging effects of both mould and mildew growth, this type of growth can occur on almost every outdoor surface and may collect on the surface of our boards. Following the steps in our Routine Cleaning section will help avoid excessive build-up of such growth.



FYLDE
DECKING
composite decking. less work. more life.

CARE GUIDE

Water Staining...

Although great care is taken in the manufacturing process of our products, residual oils can remain present in our Woodgrain and Grooved ranges, which can sometimes leach out and appear as white streaks on the surface of the deck boards.

While these water stains will gradually disappear over a period of **approximately 6-8 weeks** when the boards are exposed to rain water.

To speed the process up you can Use warm soapy water to thoroughly clean the affected boards.

Again, you may wish to use a jet wash on the affected area to assist with the removal of surface residue



FYLDE
DECKING
composite decking. less work. more life.

CARE GUIDE

Clearing Ice & Snow...

We recommend maintaining a safe deck when the winter hits by ensuring snow and ice are **thoroughly cleared from the surface.**

You can follow the points below to keep your decking protected from the effects of winter:

Avoid using metal shovels, rakes, hoes and ice chippers and any other sharp objects to clear snow or ice off your deck. Instead **use a plastic shovel**, otherwise you run the risk of scratching or damaging the surface of the boards.

We recommend using a salt-free, non-corrosive ice melt which is designed not to leave any residue on the surface of the boards and is generally more effective than salt-based alternatives. This can be laid either prior to a forecast frost or to areas where ice has already formed.

While rock salt can be used on our composite decking, we advise that this is cleared away shortly after it has been applied to ensure that it does not damage or scratch the surface of the boards.

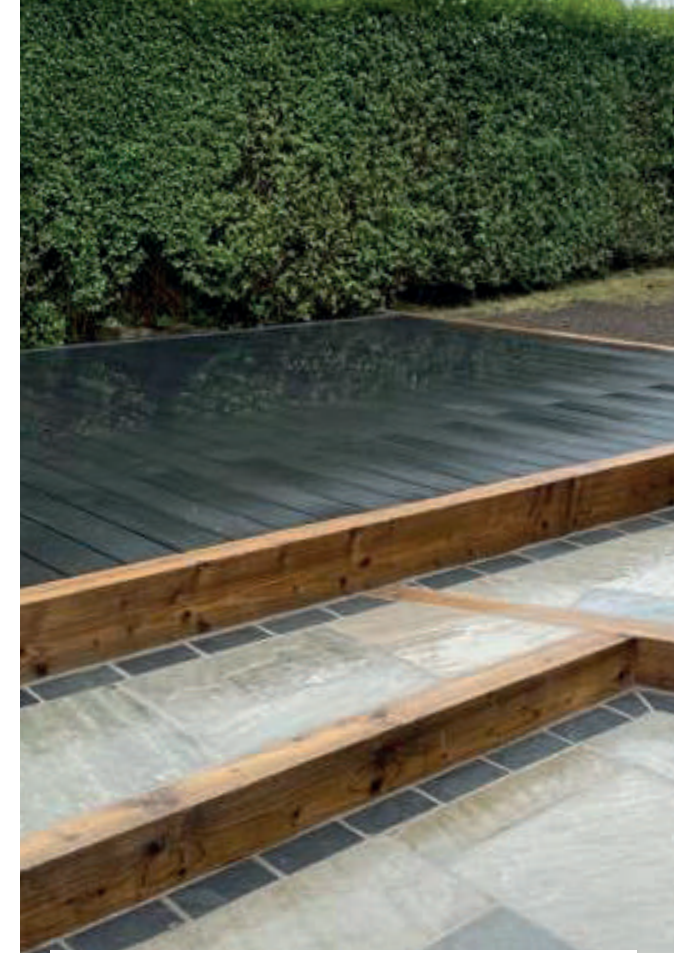

FYLDE
DECKING
composite decking. less work. more life.

FAQ'S

Frequently Asked Questions...

Q. Will the colour fade over time?

A. All of our composite decking solutions are more fade-resistant than traditional wooden decking. The decking will lighten-up in colour-tone, achieving their weathered colour after a period of up to 6 months. The level of fade hereafter will be minimal once the boards have reached this colour tone.

Q. How do your products react when exposed to water?

A. Our Fylde Decking boards are designed to take on very little water. Our ranges have a much lower absorption rate than timber which heavily reduces the likelihood of wet rot over a longer period of time.

Q. Do you have recommended installers I can use?

A. Fylde Decking has an extensive network of recommended installers who we trust to bring your plans to reality. We have chosen these installers for their high quality of work and professionalism, but as with any third party, we recommend that you follow your own precautions before entering into a contract with them.

Q. Does composite decking get hotter than wooden decking when under the sun?

A. In extensive studies, it has been found that the colour of the decking board, regardless if it's made of wood-plastic composite or wood is the most significant factor in the heat retention of the board. Naturally, the darker colour tones will warm up quicker than our lighter coloured boards. In these studies, pressure-treated wood stained the same colour was hotter in the same test conditions.

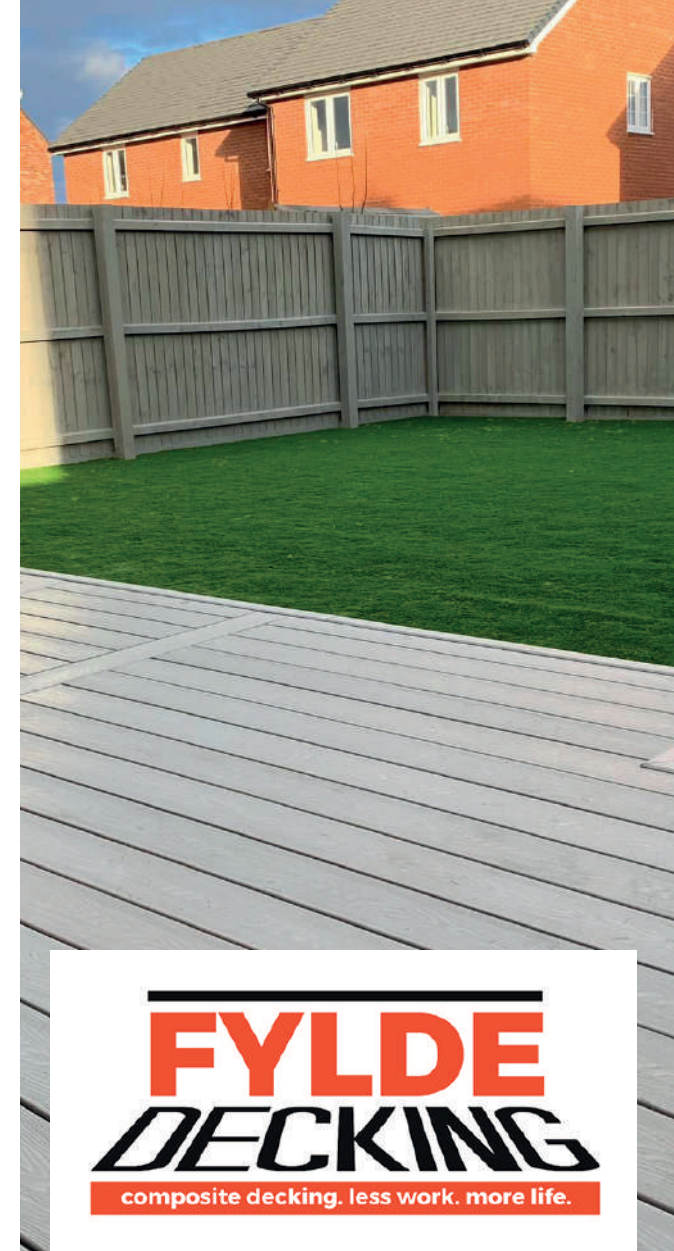

FYLDE
DECKING
composite decking. less work. more life.